



1A Adjustable/Fixed Low Dropout Linear Regulator

General Description

The AMS1117-ADJ and AMS1117-1.2,-1.5,-1.8,-2.5,-2.85,-3.3 and-5 are low dropout three-terminal regulators with 1A output current capability. These devices have been optimized for low voltage where transient response and minimum input voltage are critical. The 2.85V version is designed specifically to be used in Active Terminators for SCSI bus.

On-chip thermal limiting provides protection against any combination of overload and ambient temperatures that would create excessive junction temperatures.

Unlike PNP type regulators where up to 10% of the output current is wasted as quiescent current, the quiescent current of the AMS1117 flows into the load, increasing efficiency.

The AMS1117 series regulators are available in the industry-standard SOT-223 and TO-252 power packages.

Key Features

- Low dropout voltage
- Load regulation: 0.2% typical
- Optimized for Low Voltage
- On-chip thermal limiting
- Standard SOT-223 and TO-252 packages
- Three-terminal adjustable or fixed low dropout 1.2V,1.5V,1.8V, 2.5V, 2.85V, 3.3V, 5V. Regulators

Applications

- Active SCSI terminators
- High efficiency linear regulators
- Post regulators for switching supplies
- Battery chargers
- 12V to 5V linear regulators
- Motherboard clock supplies

Typical Application

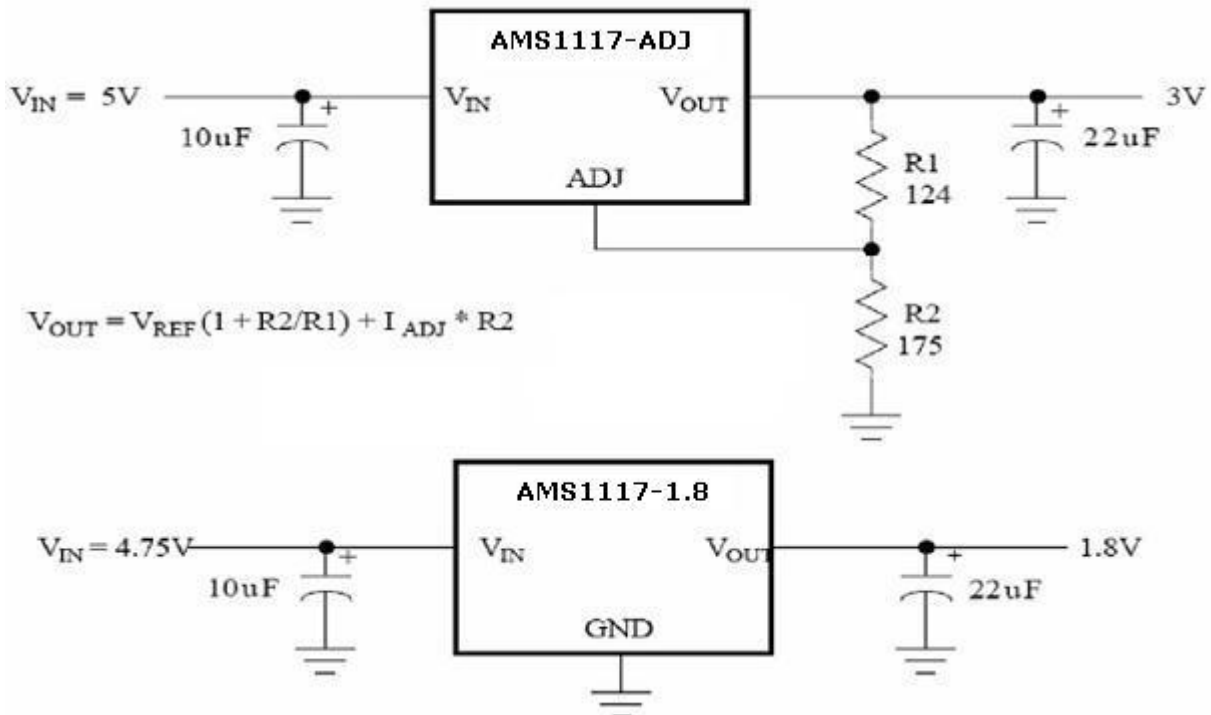

Figure 1. Typical Applications of AMS1117

Notice: The distance between Vout pin and Capacitor should not exceed 4cm for excellent performance



1A Adjustable/Fixed Low Dropout Linear Regulator

Pin Assignments

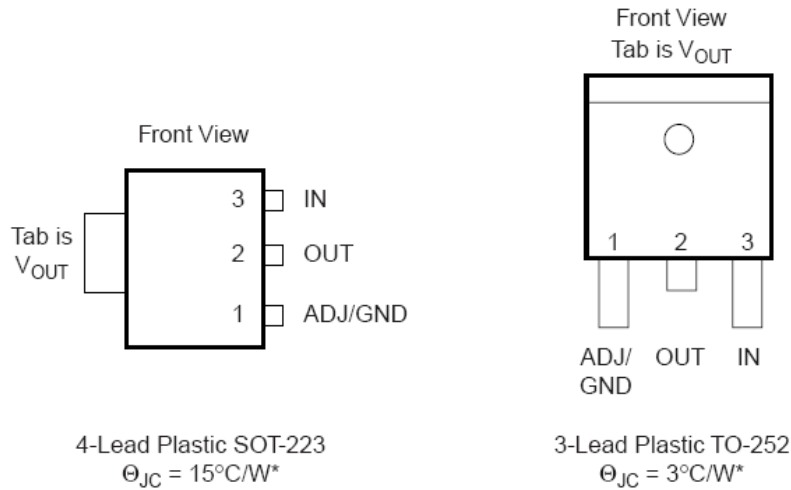

Figure 2. Pin Assignments of AMS1117

*With package soldered to 0.5 square inch copper area over backside ground plane or internal power plane, θ_{JA} can vary from 30°C/W to more than 50°C/W. Other mounting techniques may provide better thermal resistance than 30°C/W.

Absolute Maximum Ratings

| Parameter | Min. | Max. | Unit |
|--|------|--------------|------|
| V _{IN} | | 18 | V |
| (V _{IN} - V _{OUT}) * I _{OUT} | | See Figure 3 | |
| Operating Junction Temperature Range | -20 | 125 | °C |
| Storage Temperature Range | -65 | 150 | °C |
| Lead Temperature (Soldering, 10 sec.) | | 300 | °C |



1A Adjustable/Fixed Low Dropout Linear Regulator

Block Diagram

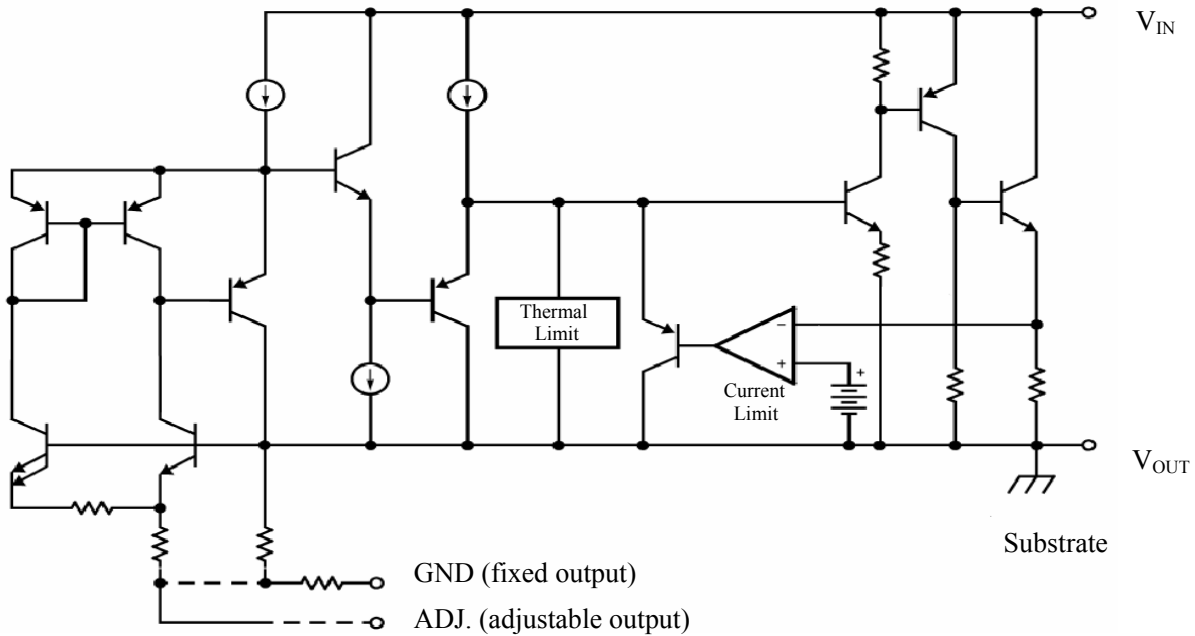

Figure 3. Block Diagram of AMS1117

Electrical Characteristic

Typicals and limits appearing in normal type apply for $T_J=25^{\circ}\text{C}$. Limits appearing in Boldface type apply over the entire junction temperature for operation, -20°C to 125°C .

| Symbol | Parameter | Conditions | Min (Note 2) | Typ (Note 1) | Max (Note 2) | Units | |
|-----------|-------------------|--|--|--------------|--------------|--------------|---|
| V_{REF} | Reference Voltage | AMS1117 $1.5\text{V} \leq (V_{IN} - V_{OUT}) \leq 7\text{V}, 10\text{mA} \leq I_{OUT} \leq 1\text{A}$ | 1.225 | 1.250 | 1.275 | V | |
| V_{OUT} | Output Voltage | $10\text{mA} \leq I_{OUT} \leq 1\text{A}$ | $I_{OUT} = 10\text{mA}, V_{IN} = 3.2\text{V}$ | 1.176 | 1.200 | 1.224 | V |
| | | | AMS1117-1.2, $2.7\text{V} \leq V_N \leq 8.2\text{V}$ | 1.152 | 1.200 | 1.248 | V |
| | | | AMS1117-1.5, $3.0\text{V} \leq V_N \leq 8.5\text{V}$ | 1.470 | 1.500 | 1.530 | V |
| | | | AMS1117-1.8, $3.3\text{V} \leq V_N \leq 8.8\text{V}$ | 1.764 | 1.800 | 1.836 | V |
| | | | AMS1117-2.5, $4\text{V} \leq V_N \leq 9.5\text{V}$ | 2.450 | 2.500 | 2.550 | V |
| | | | AMS1117-2.85, $4.35\text{V} \leq V_{IN} \leq 9.85\text{V}$ | 2.793 | 2.850 | 2.907 | V |
| | | | AMS1117-3.3, $4.8\text{V} \leq V_N \leq 10.3\text{V}$ | 3.234 | 3.300 | 3.366 | V |
| | | | AMS1117-5.0, $6.5\text{V} \leq V_N \leq 12\text{V}$ | 4.900 | 5.000 | 5.100 | V |



1A Adjustable/Fixed Low Dropout Linear Regulator

Electrical Characteristic (Continued)

Typicals and limits appearing in normal type apply for $T_J=25^\circ\text{C}$. Limits appearing in Boldface type apply over the entire junction temperature for operation, -20°C to 125°C .

| Symbol | Parameter | Conditions | Min (Note 2) | Typ (Note 1) | Max (Note 2) | Units |
|---------------------|--|---|--------------|--------------|--------------|---------------|
| ΔV_{OUT} | Line Regulation (Note 3) | $I_{OUT}=10\text{mA}, (V_{OUT}+1.5\text{V})\leq V_{IN}\leq 12\text{V}$ | | 0.035 | 0.2 | % |
| | Load Regulation (Note 3) | $V_{IN}-V_{OUT}=2\text{V}, 10\text{mA}\leq I_{OUT}\leq 1\text{A},$ | | 0.2 | 0.7 | % |
| | | AMS1117-1.2 $V_{IN}-V_{OUT}=2\text{V}, 10\text{mA}\leq I_{OUT}\leq 1\text{A},$ | | 0.2 | 1 | % |
| $V_{IN}-V_{OUT}$ | Dropout Voltage | $I_{OUT}=1\text{A}, \Delta V_{REF}=1\%$ | | 1.100 | 1.250 | V |
| I_{Limit} | Current Limit | $V_{IN}-V_{OUT}=2\text{V}, T_J=25^\circ\text{C}$ | 1.1 | 1.5 | | A |
| | Minimum Load Current (Note 4) | AMS1117-ADJ $1.5\text{V}\leq (V_{IN}-V_{OUT})\leq 10\text{V}$ | 10 | | | mA |
| | Quiescent Current | $V_{IN}=V_{OUT}+1.25\text{V}$ | | 5 | 13 | mA |
| | Thermal Regulation | $T_A = 25^\circ\text{C}, 30\text{ms pulse}$ | | 0.01 | 0.1 | %/W |
| | Ripple Rejection | $f=120\text{Hz}, V_{IN}-V_{OUT}=3\text{V}, V_{Ripple}=1\text{V}_{PP}$ | 60 | 72 | | dB |
| | Adjust Pin Current | | | 50 | 120 | μA |
| | Adjust Pin Current Change | $1.5\text{V}\leq V_{IN}-V_{OUT}\leq 7\text{V}, 10\text{mA}\leq I_{OUT}\leq 1\text{A}$ | | 0.2 | 5 | μA |
| | Temperature Stability | | | 0.5 | | % |
| Long Term Stability | $T_A = 125^\circ\text{C}, 1000\text{hrs.}$ | | 0.3 | | % | |



1A Adjustable/Fixed Low Dropout Linear Regulator

Electrical Characteristic (Continued)

Typicals and limits appearing in normal type apply for $T_J=25^{\circ}\text{C}$. Limits appearing in Boldface type apply over the entire junction temperature for operation, -20°C to 125°C .

| Symbol | Parameter | Conditions | Min (Note 2) | Typ (Note 1) | Max (Note 2) | Units |
|-------------|--------------------------------------|---|--------------|--------------|--------------|-----------------------------|
| I_{Limit} | RMS Output Noise(% of V_{OUT}) | $T_A = 25^{\circ}\text{C}$, $10\text{Hz} \leq f \leq 10\text{kHz}$ | | 0.003 | | % |
| | Thermal Resistance, Junction to Case | SOT-223 | | 15 | | $^{\circ}\text{C}/\text{W}$ |
| | | TO-252 | | 3 | | $^{\circ}\text{C}/\text{W}$ |
| | Thermal Shutdown | Junction Temperature | | 155 | | $^{\circ}\text{C}$ |
| | Thermal Shutdown Hysteresis | | | 25 | | $^{\circ}\text{C}$ |

- Note 1:** Typical Values represent the most likely parametric norm.
- Note 2:** All limits are guaranteed by testing or statistical analysis.
- Note 3:** Load and line regulation are measured at constant junction room temperature.
- Note 4:** The minimum output current required to maintain regulation.

Typical Performance Characteristics

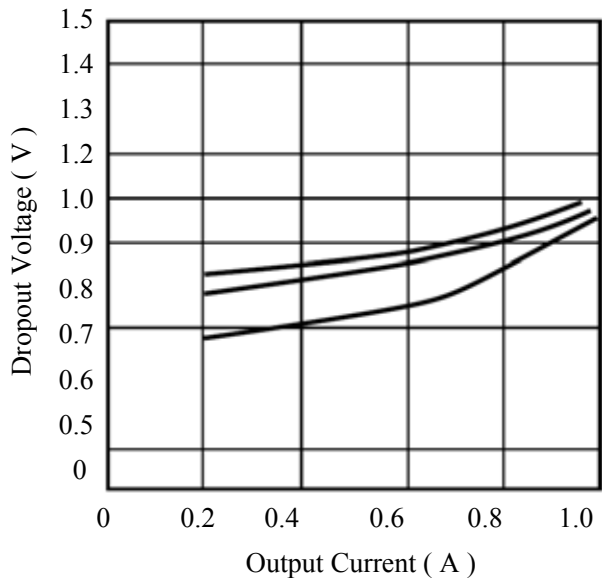

Figure 4. Dropout Voltage VS. Output Current



1A Adjustable/Fixed Low Dropout Linear Regulator

Typical Performance Characteristics

(Continued)

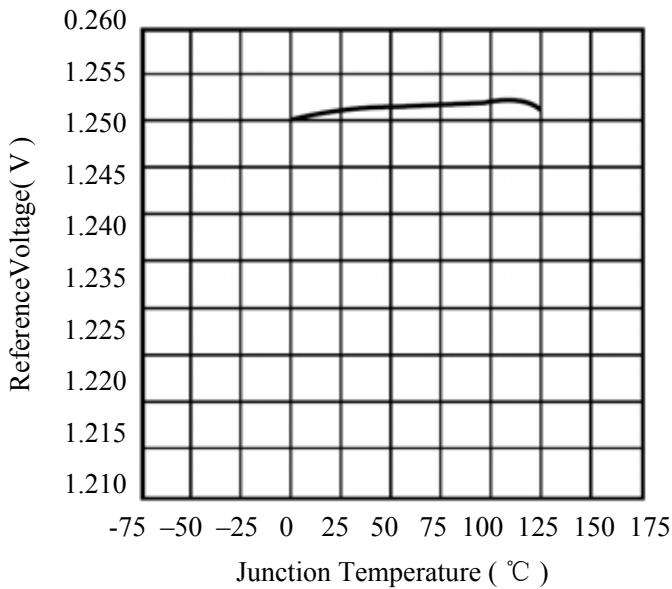

Figure 5. Reference Voltage VS. Temperature

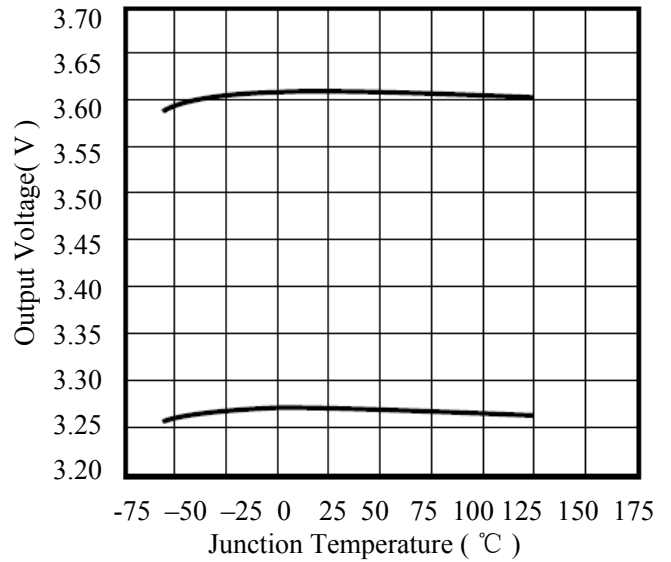

Figure 6. Output Voltage VS. Temperature

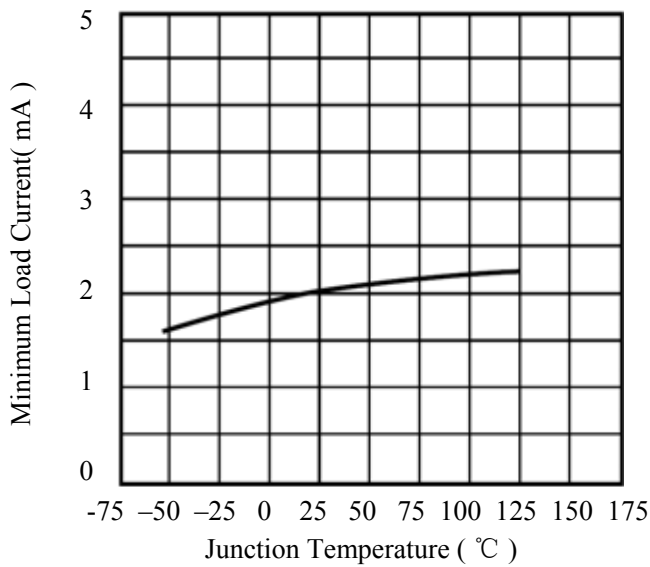

Figure 7. Minimum Load Current VS. Temperature

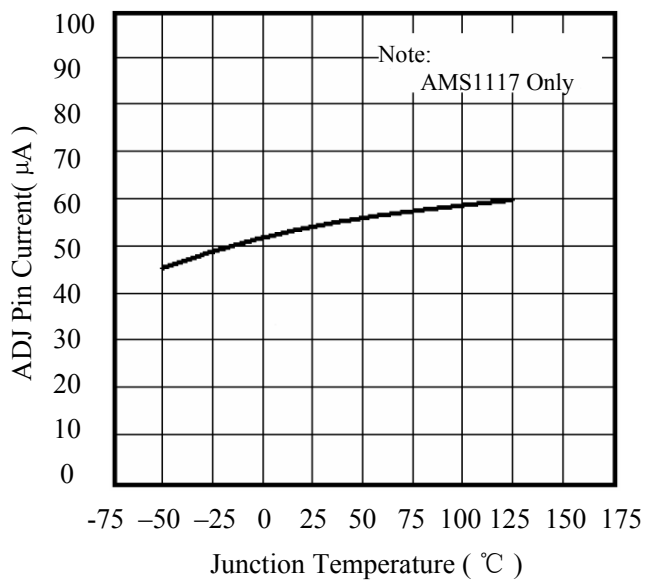

Figure 8. ADJ Pin Current VS. Temperature



1A Adjustable/Fixed Low Dropout Linear Regulator

Mechanical Dimensions

4-Lead SOT-223 Package

| Symbol | Inches | | Millimeters | | Notes |
|--------|--------|-------|-------------|-------|-------|
| | Min. | Max. | Min. | Max. | |
| A | Ñ | .071 | Ñ | 1.80 | |
| A1 | Ñ | .181 | Ñ | 4.80 | |
| B | .025 | .033 | .064 | .840 | |
| c | Ñ | 0.90 | Ñ | 2.29 | |
| D | .248 | .264 | 6.30 | 6.71 | |
| E | .130 | .148 | 3.30 | 3.71 | |
| e | .115 | .124 | 2.95 | 3.15 | |
| F | .033 | .041 | .840 | 1.04 | |
| H | .264 | .287 | 6.71 | 7.29 | |
| I | .0121 | Ñ | .310 | Ñ | |
| J | Ñ | 10° | Ñ | 10° | |
| K | 10° | 16° | 10° | 16° | |
| L | .0008 | .0040 | .0203 | .1018 | |
| M | 10° | 16° | 10° | 16° | |
| N | .010 | .014 | .250 | .360 | |

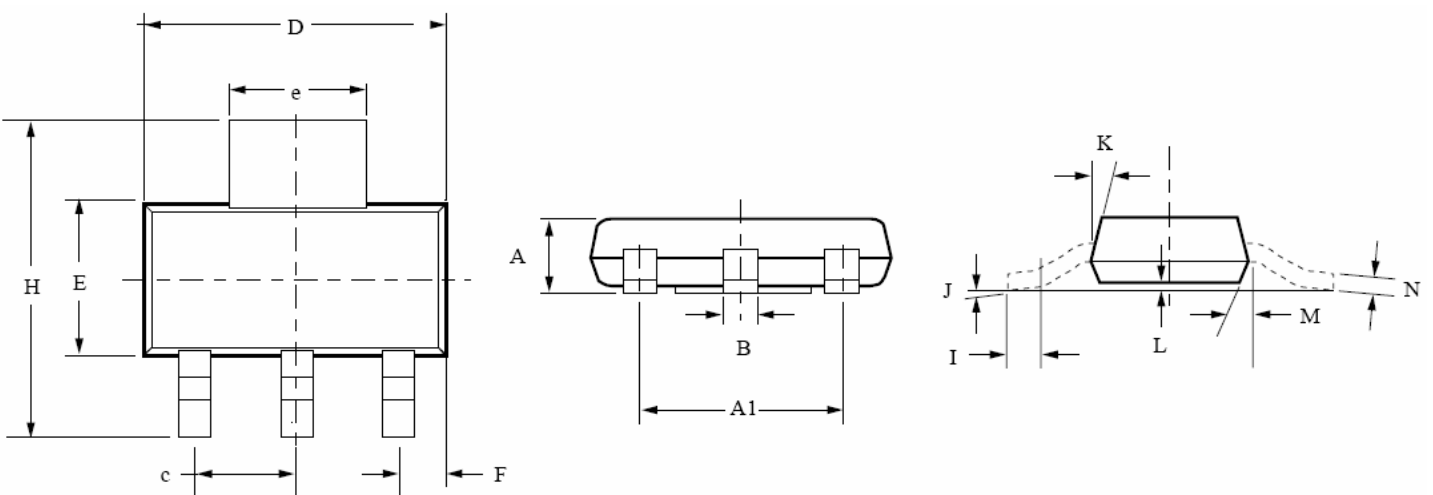

Figure 9. 4-Lead SOT-223 Package



1A Adjustable/Fixed Low Dropout Linear Regulator

Mechanical Dimensions (Continued)

3-Lead TO-252 Package

| Symbol | Inches | | Millimeters | | Notes |
|--------|----------|------|-------------|-------|-------|
| | Min. | Max. | Min. | Max. | |
| A | .086 | .094 | 2.19 | 2.39 | |
| b | .025 | .035 | 0.64 | 0.89 | |
| b2 | .030 | .045 | 0.76 | 1.14 | |
| b3 | .205 | .215 | 5.12 | 5.46 | 4 |
| c | .018 | .024 | 0.46 | 0.61 | |
| c2 | .018 | .023 | 0.46 | 0.58 | |
| D | .210 | .245 | 5.33 | 6.22 | 1 |
| E | .250 | .265 | 6.35 | 6.73 | 1 |
| e | .090 BSC | | 2.29 BSC | | |
| H | .370 | .410 | 9.40 | 10.41 | |
| L | .055 | .070 | 1.40 | 1.78 | 3 |
| L1 | .108 REF | | 2.74 REF | | |
| L3 | .035 | .080 | 0.89 | 2.03 | 4 |
| L4 | .025 | .040 | 0.64 | 1.02 | |

Notes:

1. Dimensions are exclusive of mold flash, metal burrs or interlead protrusion.
2. Stand off-height is measured from lead tip with ref. to Datum -B-.
3. Foot length is measured with ref. to Datum -A- with lead surface.
4. Thermal pad contour optional within dimension b3 and L3.
5. Formed leads to be planar with respect to one another at seating place -C-.
6. Dimensions and tolerances.

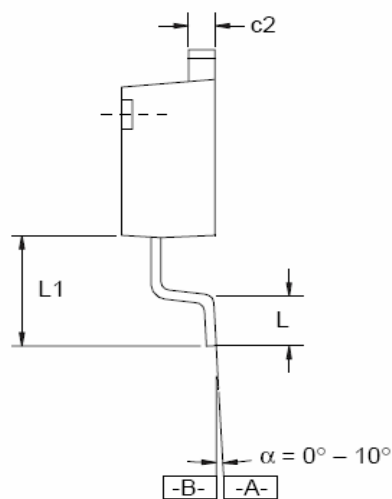
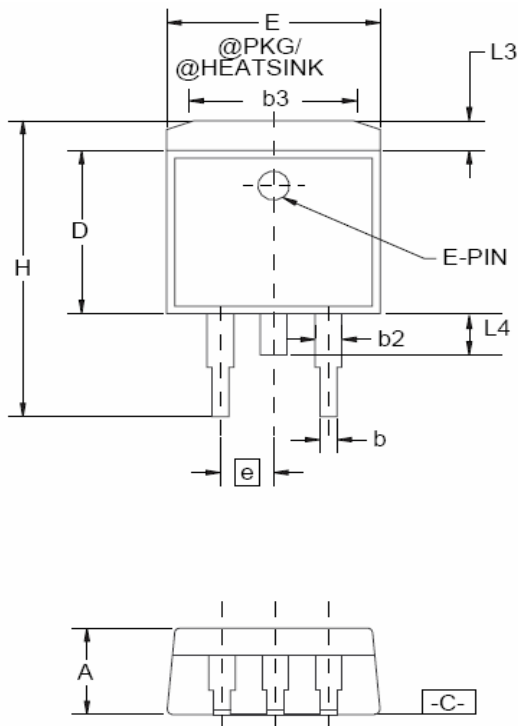

Figure 10. 3-Lead TO-252 Package



1A Adjustable/Fixed Low Dropout Linear Regulator

Ordering Information

| Package | Temperature Range | Part Number | Output Voltage | Packing Marking | Transport Media |
|---------|-------------------|--------------|----------------|-----------------|--------------------|
| SOT-223 | -20°C - +125°C | AMS1117-1.2 | 1.2V | AMS1117 1.2 | 2.5K Tape and Reel |
| | -20°C - +125°C | AMS1117-1.5 | 1.5V | AMS1117 1.5 | 2.5K Tape and Reel |
| | -20°C - +125°C | AMS1117-1.8 | 1.8V | AMS1117 1.8 | 2.5K Tape and Reel |
| | -20°C - +125°C | AMS1117-2.5 | 2.5V | AMS1117 2.5 | 2.5K Tape and Reel |
| | -20°C - +125°C | AMS1117-2.85 | 2.85V | AMS1117 2.8 | 2.5K Tape and Reel |
| | -20°C - +125°C | AMS1117-3.3 | 3.3V | AMS1117 3.3 | 2.5K Tape and Reel |
| | -20°C - +125°C | AMS1117-5 | 5V | AMS1117 5 | 2.5K Tape and Reel |
| | -20°C - +125°C | AMS1117 | Adjust | AMS1117 | 2.5K Tape and Reel |
| TO-252 | -20°C - +125°C | AMS1117-1.2 | 1.2V | AMS1117 1.2 | 2.5K Tape and Reel |
| | -20°C - +125°C | AMS1117-1.5 | 1.5V | AMS1117 1.5 | 2.5K Tape and Reel |
| | -20°C - +125°C | AMS1117-1.8 | 1.8V | AMS1117 1.8 | 2.5K Tape and Reel |
| | -20°C - +125°C | AMS1117-2.5 | 2.5V | AMS1117 2.5 | 2.5K Tape and Reel |
| | -20°C - +125°C | AMS1117-2.85 | 2.85V | AMS1117 2.8 | 2.5K Tape and Reel |
| | -20°C - +125°C | AMS1117-3.3 | 3.3V | AMS1117 3.3 | 2.5K Tape and Reel |
| | -20°C - +125°C | AMS1117-5 | 5.0V | AMS1117 5 | 2.5K Tape and Reel |
| | -20°C - +125°C | AMS1117CD | Adjust | AMS1117CD | 2.5K Tape and Reel |

Advanced Monolithic Systems

<http://www.ams-semitech.com>

Disclaimer:

- AMS reserves the right to make changes to the information herein for the improvement of the design and performance without further notice! Customers should obtain the latest relevant information before placing orders and should verify that such information is complete and current.
- All semiconductor products malfunction or fail with some probability under special conditions. When using AMS products in system design or complete machine manufacturing, it is the responsibility of the buyer to comply with the safety standards strictly and take essential measures to avoid situations in which a malfunction or failure of such AMS products could cause loss of body injury or damage to property.
- AMS will supply the best possible product for customers!

The "S" logo is a registered trademark of Advanced Monolithic Systems.
All other company and product names are trademarks of their respective owners