

NPN Transistors

 Lead(Pb)-Free

TO-92

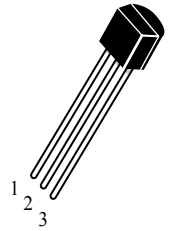

1. EMITTER
2. COLLECTOR
3. BASE

MAXIMUM RATINGS

Rating	Symbol	Value	Unit
Collector-Emitter Voltage	V_{CEO}	50	Vdc
Collector-Base Voltage	V_{CBO}	60	Vdc
Emitter-Base Voltage	V_{EBO}	5.0	Vdc
Collector Current-Continuous	I_C	150	mAdc
Total Device Dissipation $T_A=25^{\circ}\text{C}$	P_D	0.4	W
Junction Temperature	T_J	+150	$^{\circ}\text{C}$
Storage Temperature	T_{STG}	-40 to + 150	$^{\circ}\text{C}$

ELECTRICAL CHARACTERISTICS

Characteristics	Symbol	Min	Max	Unit
-----------------	--------	-----	-----	------

OFF CHARACTERISTICS

Collector-Emitter Breakdown Voltage ($I_C=100\ \mu\text{Adc}, I_E=0$)	$V_{(BR)CEO}$	50	-	Vdc
Collector-Base Breakdown Voltage ($I_C=1\ \text{mAdc}, I_E=0$)	$V_{(BR)CBO}$	60	-	Vdc
Emitter-Base Breakdown Voltage ($I_E=100\ \mu\text{Adc}, I_C=0$)	$V_{(BR)EBO}$	5.0	-	Vdc
Collector Cutoff Current ($V_{CE}=60\ \text{Vdc}, I_E=0$)	I_{CEO}	-	0.1	μAdc
Collector Cutoff Current ($V_{CB}=45\ \text{Vdc}, I_E=0$)	I_{CBO}	-	0.1	μAdc
Emitter Cutoff Current ($V_{EB}=5.0\ \text{Vdc}, I_C=0$)	I_{EBO}	-	0.1	μAdc

ELECTRICAL CHARACTERISTICS ($T_A=25^\circ\text{C}$ unless otherwise noted) (Continued)

Characteristics	Symbol	Min	Typ	Max	Unit
-----------------	--------	-----	-----	-----	------

ON CHARACTERISTICS

DC Current Gain $V_{CE}=6.0\text{V}$, $I_C=1\text{mA}$ $V_{CE}=6.0\text{V}$, $I_C=0.1\text{mA}$	h_{FE1} h_{FE2}	70 40	-	700	-
Collector-Emitter Saturation Voltage $I_C=100\text{mA}$, $I_B=10\text{mA}$	$V_{CE(sat)}$	-	-	0.3	V
Base-Emitter Voltage $I_C=100\text{mA}$, $I_B=10\text{mA}$	$V_{BE(sat)}$	-	-	1.0	V
Transition Frequency $V_{CE} = 6\text{V}$, $I_C = 10\text{mA}$, $f = 30\text{MHz}$	f_T	200	-	-	MHz
Collector Output Capacitance $V_{CB} = 10\text{V}$, $I_E = 0$, $f = 1\text{MHz}$	C_{ob}	-	-	3.0	pF
Noise figure $V_{CE} = 6\text{V}$, $I_C = 0.1\text{mA}$, $R_g = 10\text{k}\Omega$, $f = 1\text{KHz}$	NF	-	4.0	10	dB

CLASSIFICATION OF h_{FE1}

Rank	O	Y	GR	BL
Range	70-140	120-240	200-400	350-700

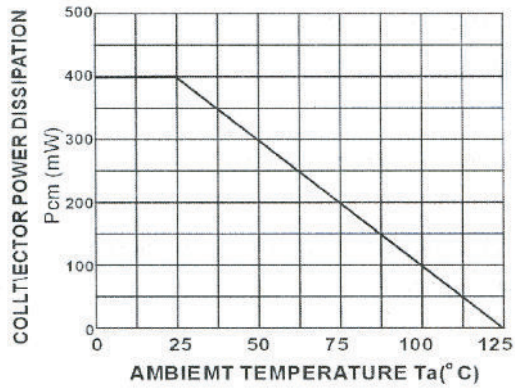

FIG1. Total Power Dissipation vs Ambient Temperature

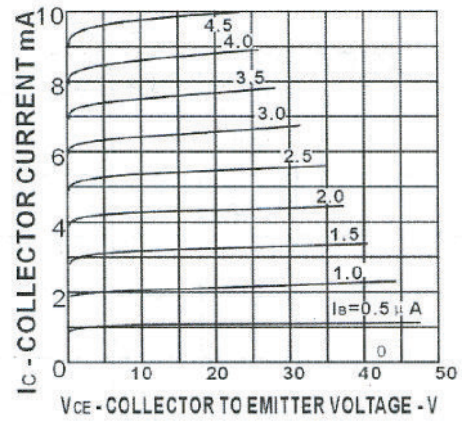

FIG.2 Collector Current vs Collector to Emitter Voltage

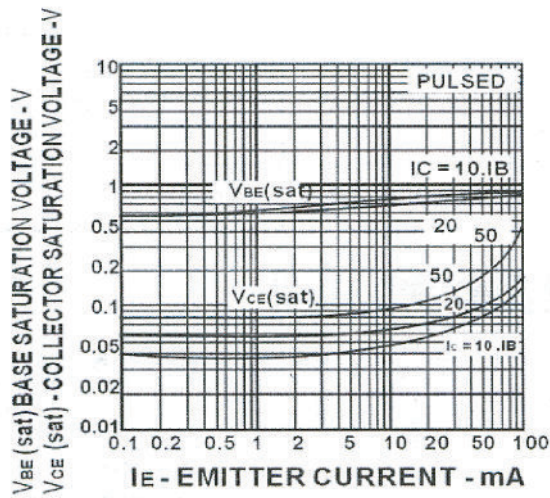

FIG.3 Collector and Base Saturation Voltage vs Collector Current

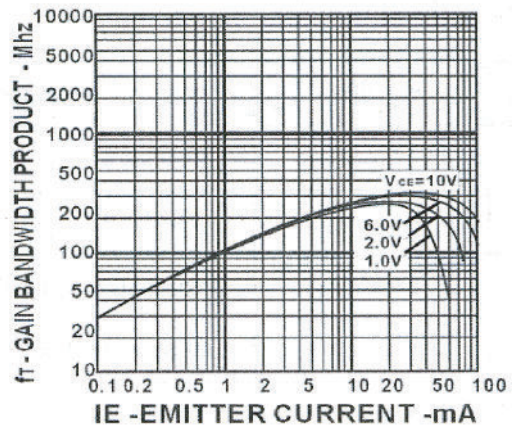
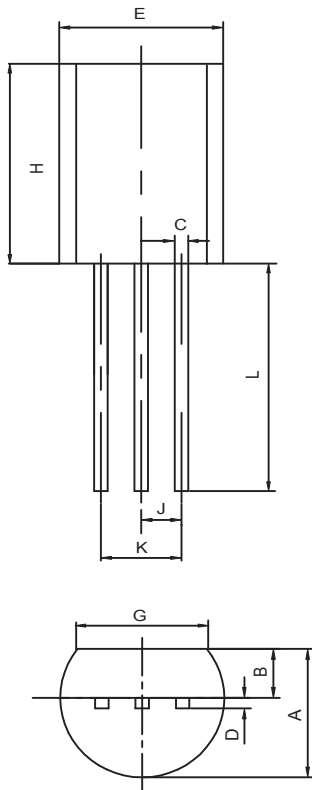

FIG.4 Gain Bandwidth Product vs Emitter Current

TO-92 Outline Dimensions

unit:mm



TO-92		
Dim	Min	Max
A	3.30	3.70
B	1.10	1.40
C	0.38	0.55
D	0.36	0.51
E	4.40	4.70
G	3.43	-
H	4.30	4.70
J	1.270TYP	
K	2.44	2.64
L	14.10	14.50