TS02N (2-CH Sensitivity Calibration Capacitive Touch Sensor)

TS02N SPECIFICATION V2.0



TS02N (2-CH Sensitivity Calibration Capacitive Touch Sensor)

1 Specification

1.1 General Feature

- 2-Channel capacitive touch sensor embedded self sensitivity calibration
- Low power consumption
- Sync function for parallel operation
- Adjustable sense frequency by RB resister
- Open-drain digital output
- Embedded noise elimination circuit
- Embedded Internal power reset circuit

1.2 Application

- Home application (White goods, blue goods etc)
- Membrane switch replacement
- Human interface for toys & interactive games
- Sealed control panels, keypads

1.3 Package (8 SOP)

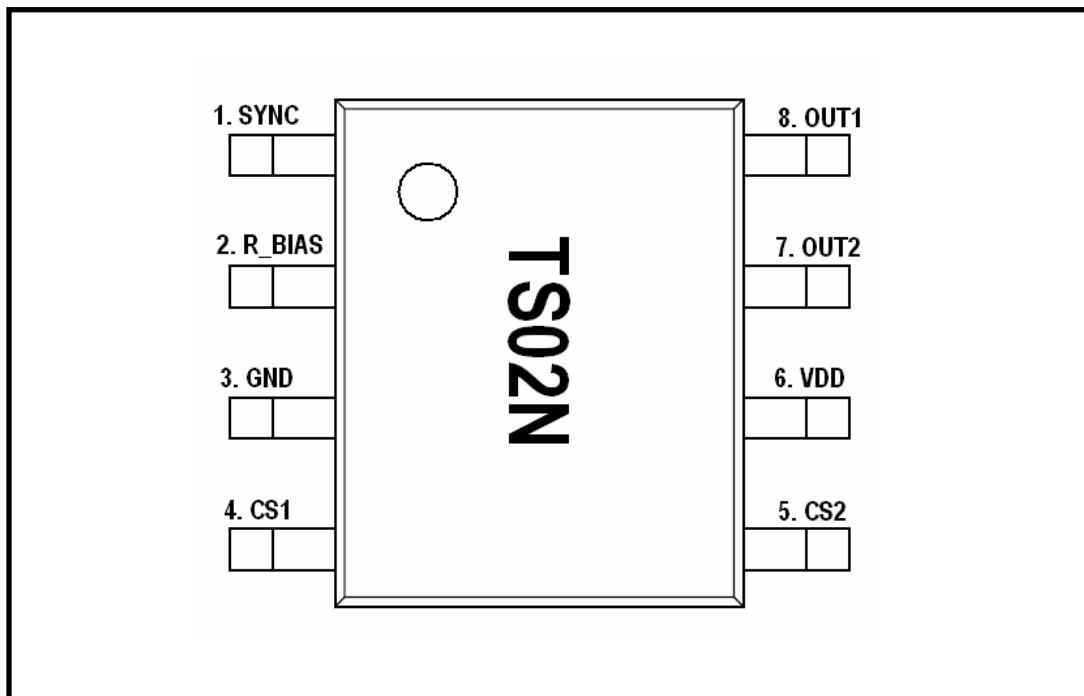

Fig.1 TS02N 8SOP (Drawings not to scale)

TS02N (2-CH Sensitivity Calibration Capacitive Touch Sensor)

2 Pin Description (8 SOP)

PIN Number	Name	I/O	Description	Protection
1	SYNC	Analog Input	Self sense operation signal output Peripheral sense operation signal input	VDD/GND
2	R_BIAS	Analog Input	Internal bias adjust input	VDD/GND
3	GND	Ground	Supply ground	VDD
4	CS1	Analog Input	Sense channel 1	VDD/GND
5	CS2	Analog Input	Sense channel 2	VDD/GND
6	VDD	Power	Power (2.5V ~ 5.0V)	GND
7	OUT2	Digital Output	Ch2 touch detect output Open drain output (Active Low)	VDD/GND
8	OUT1	Digital Output	Ch1 touch detect output Open drain output (Active Low)	VDD/GND

3 Absolute Maximum Rating

Supply voltage	5.0V
Maximum voltage on any pin	VDD+0.3 V
Maximum current on any PAD	100mA
Power Dissipation	800mW
Storage Temperature	-50 ~ 150°C
Operating Temperature	-20 ~ 75°C
Junction Temperature	150°C

Characteristics	Symbol	Test Condition	Min	Typ	Max	Units
Supply Voltage	V _{DD}	–	2.5	3.3	5.0	V
Current consumption	I _{D_MAX}	-20°C < T _a < +75°C, V _{DD} = 3.3V	–	–	180	μA
Power dissipation	P _D	-20 ~ 75°C, V _{DD} = 5V	–	–	800	mW

3.1 ESD Characteristics

Mode	Polarity	Max	Reference
H.B.M	Pos / Neg	2000V	VDD
		2000V	VSS
		2000V	P to P
M.M	Pos / Neg	200V	VDD
		200V	VSS
		200V	P to P
C.D.M	Pos / Neg	800V	DIRECT

3.2 Latch-up Characteristics

Mode	Polarity	Max	Test Step
I Test	Positive	200mA	25mA
	Negative	-200mA	
V supply over 5.0V	Positive	8.0V	1.0V

TS02N (2-CH Sensitivity Calibration Capacitive Touch Sensor)

4 Electrical Characteristics

▪ $V_{DD}=3.3V$, $R_B=510k$, (Unless otherwise noted), $T_A = 25^\circ C$

Characteristics	Symbol	Test Condition	Min	Typ	Max	Units
Operating supply voltage	V_{DD}		2.5	3.3	5.0	V
Current consumption	I_{DD}	$V_{DD}= 3.3V$ $R_B=510k$ slow mode	–	50	70	μA
Output maximum sink current	I_{OUT}	$T_A = 25^\circ C$	–	–	4.0	mA
Input capacitance range Note1	C_S		–	4.0	100	pF
Minimum detective capacitance difference	ΔC	$C_S = 4pF$	–	0.1	–	pF
Output impedance (open drain)	Z_O	$\Delta C > 0.1pF$	–	12	–	Ω
		$\Delta C < 0.1pF$	–	30M	–	
Self calibration time	T_{CAL}	After reset $V_{DD} = 3.3V$ $R_B = 510k$	–	200	–	ms
Burst sense oscillation period	T_P	BF(Burst Fast) mode	–	10	–	ms
		BS(Burst Slow) mode	–	80	–	
Bias Resistance Range Note2	R_B		200	510	820	k Ω
Sync pin output source current	I_{SYNC}	$V_{DD}= 3.3V$ $R_B=510k$	–	50	–	μA
Sync pin high threshold voltage	V_H	$V_{DD}= 3.3V$	–	2.6	–	V
Sync pin low threshold voltage	V_L	$V_{DD}= 3.3V$	–	0.6	–	V

Note 1 : Sensitivity can be raised with lower C_S value

Note 2 : Lower R_B is recommended in noisy condition.

TS02N (2-CH Sensitivity Calibration Capacitive Touch Sensor)

5 Implementation of TS02N

5.1 R_BIAS implementation

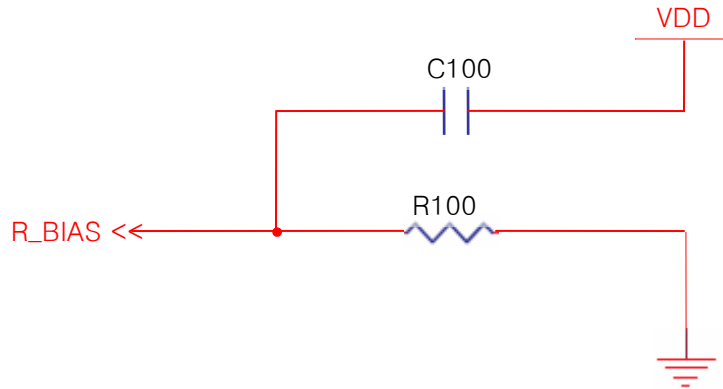

R_BIAS is connecting to the resistor to decide the oscillator and internal bias current. The sensing frequency, internal clock frequency and current consumption are therefore able to be adjustable with R100. Voltage ripple on R_BIAS can make critical internal error, so C100 connected to the VDD recommended. (Typical Value of C100 is 1nF)

Table1. Frequency & IDD @ 25 °C

Condition		SLOW MODE
VDD [V]	R100 [kOhm]	Current Consumption [uA]
5.0	510	110
3.3	510	50
2.5	510	35

TS02N (2-CH Sensitivity Calibration Capacitive Touch Sensor)

5.2 CS implementation

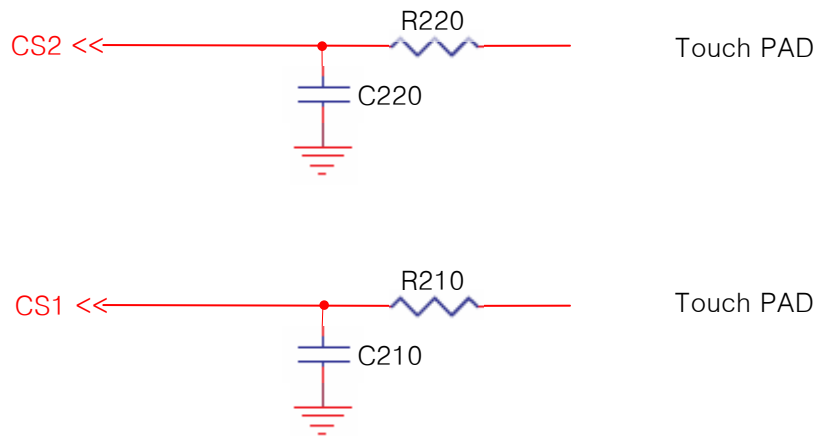

Parallel capacitor C220 is added to CS2 and C210 to CS1 to adjust the sensitivity of initial touch detect condition. The sensitivity will be increased when C220 and C210 value are smaller. It could be useful in case of detail sensitivity mediation is required. The TS02N has two independent touch sensor input CS1 and CS2. Internal touch decision processes of CS1 and CS2 are separated from each other. Therefore two channel touch key board can be designed by using only one TS02N. R210 and R220 are serial connection resistors to avoid mal-function from external surge and ESD. From 200 Ω to 1k Ω is recommended for R210 and R220 values. The size and shape of PAD might be an influence on the sensitivity. The sensitivity will be increased when the larger PAD is used because the frequency variation caused by touch PAD. The connection line of CS1 and CS2 to touch PAD is recommended to be routed as short as possible to prevent from abnormal touch detect caused by connection line.

5.3 SYNC implementation

Over two TS02N can be working on the one application at the same time thanks to SYNC function with this pin. The SYNC pulse prevents over two sensing signal from interfering with each other. The R400 is pull-down resistor of SYNC pin. Too much big value of R400 makes the SYNC pulse falling delay, and too much small value of R400 makes rising delay. About 20M Ω is recommended for R400 value. The Sync pin should be implemented as below for this. TS02N also can be used with the other TSxx series by employing this SYNC function.

TS02N (2-CH Sensitivity Calibration Capacitive Touch Sensor)

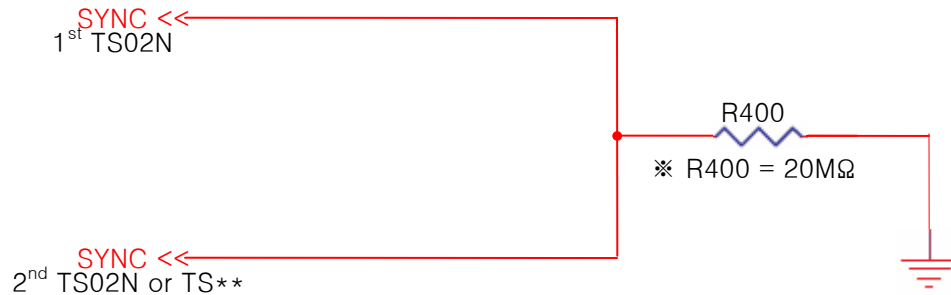
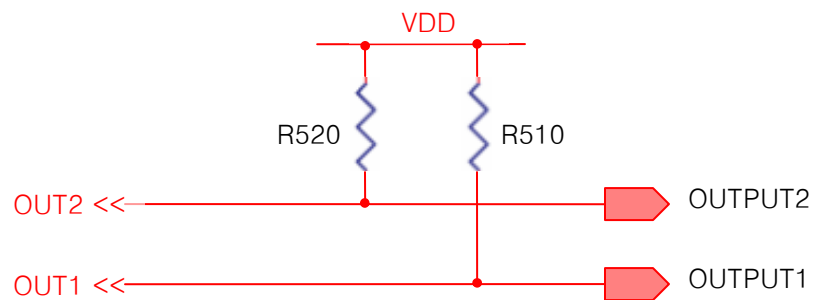

Table2. SYNC pin option

Connection	Operation
R400 Connection	Normal SYNC operation with the other TSXX series / High Sensitivity Application
GND	No SYNC / Low Sensitivity Application
VDD	Forbidden

5.4 OUTPUT implementation



The OUT1 and OUT2 are an open drain structure. For this reason the connection of pull-up resistor R510 and R520 are required between OUT1, OUT2 and VDD. The reset value of OUT1 and OUT2 is high, and the value is low during a touch is detected on CS1 or CS2. Over few kΩ resistors are recommended as R510 and R520.

TS02N (2-CH Sensitivity Calibration Capacitive Touch Sensor)

6 Recommended Circuit (Example)

Two channel touch key board can be designed by using only one TS02N. The TS02N is embedded intelligent internal power reset circuit that makes possible to save circuit cost because of reducing external components for reset. The sensitivity calibration operation can help to prevent abnormal detection caused by external noise, temperature variation, and supply voltage drop.

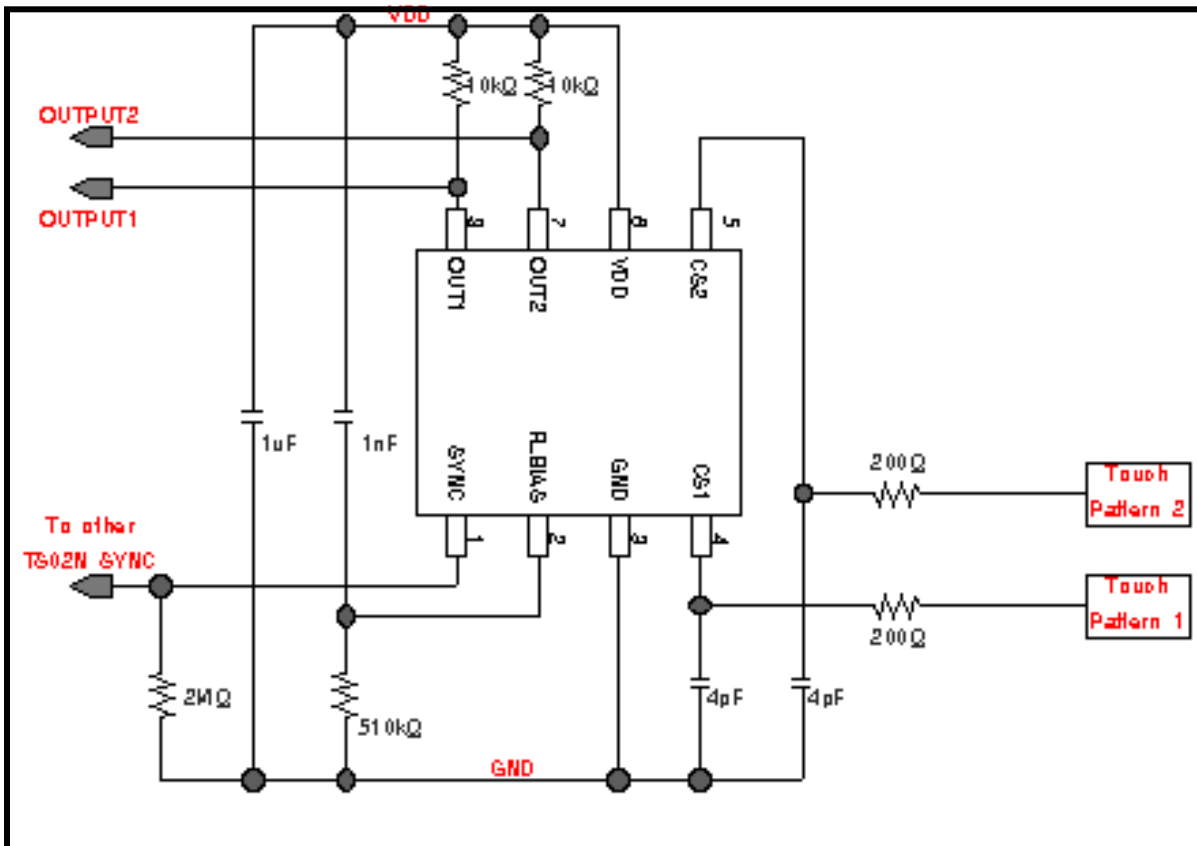
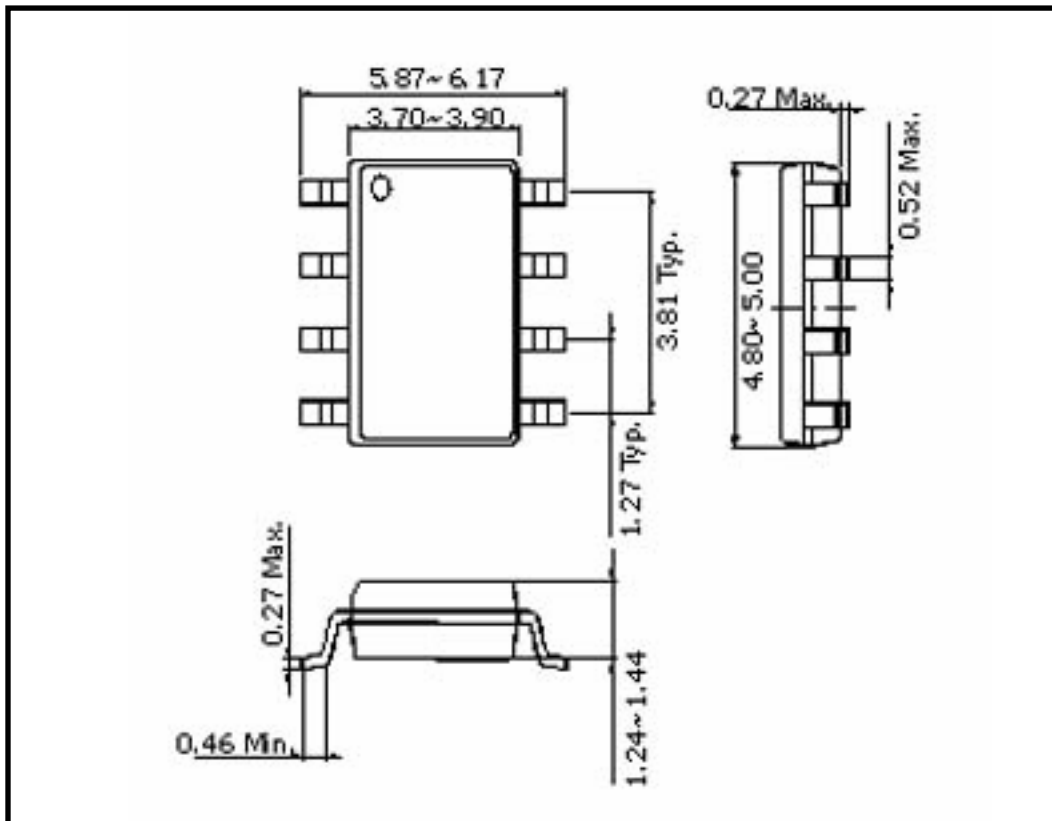

Fig.2 TS02N Application Example Circuit

TS02N (2-CH Sensitivity Calibration Capacitive Touch Sensor)

7 MECHANICAL DRAWING



Recommended Soldering Profiles

Wave Soldering

		Wave Solder
Ramp Up (C/sec)	Recommended	4 C/sec
Solder Temperature	Maximum	235 C
Dwell Time	Maximum	3 seconds
Ramp Down	Recommended	4 C/sec

IR Convection / Vapor Phase Reflow – Surface Mount

		Convection / IR	Vapor Phase
Ramp Up (C/sec)	Recommended	2 C/sec	2 C/sec
Solder Temperature	Maximum	220 C	215 C
Dwell Time	Maximum	15 seconds	60 seconds
Ramp Down	Recommended	2 C/sec	2 C/sec

LIFE SUPPORT POLICY

touchSEMI PRODUCTS ARE NOT AUTHORIZED FOR USE AS CRITICAL COMPONENTS IN LIFE SUPPORT DEVICES NOR SYSTEMS WITHOUT THE EXPRESS WRITTEN APPROVAL OF THE PRESIDENT AND GENERAL COUNSEL OF THE EPSILLON COMPANY.
touchSEMI IS MEMBER OF EPSILLON COMPANY.

touchSEMI Sales Office

touchSEMI

www.touchsemi.com

Tel.: (+420) 212247491

Fax: (+420) 212247466

**Na mokrině 45, 130 00 Prague 3
Czech Republic, EU**
